

Horizontal Automatic Packaging Machine

SDXD-15



Horizontal Automatic Packaging Machine

The **SDXD-15** can pack powders, granules, liquids, pastes and so on with the mode of three side or four side sealed sachets. It is the packaging machine in foodstuff, pharmaceutical and cosmetic industry which is your best choice.



Features:

- Up to 80 pouches/min.
- Producing speed is high.
- Changing the size is easy.
- Product's package is beautiful, and the sealing site is not stained with fluid or powder, so the package is firm.
- Wrapping Material: All kinds of multilayer heat-sealable films.

Volumetric Cup Filing Device
(Granule)



Auger Filler Device
(Powder)



Gravity Dosing Device
(Liquids)



Piston Pump Filling Device
(Creams and Pastes)

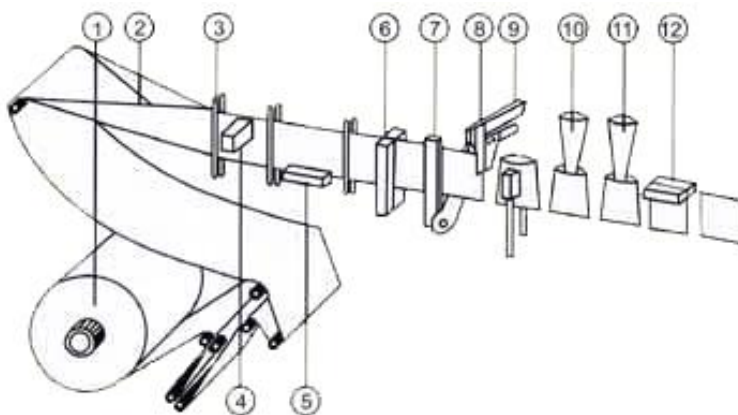

Work Flow:

1. Reel of material
2. "V" Formation
3. Folding guides
4. Optical sensor
5. 4TH seal
6. Vertical sealing jaws
7. Scissors
8. Pulling Fingers
9. Opener
10. Discharge funnel
11. Discharge funnel
12. Upper seal

Dimensions:

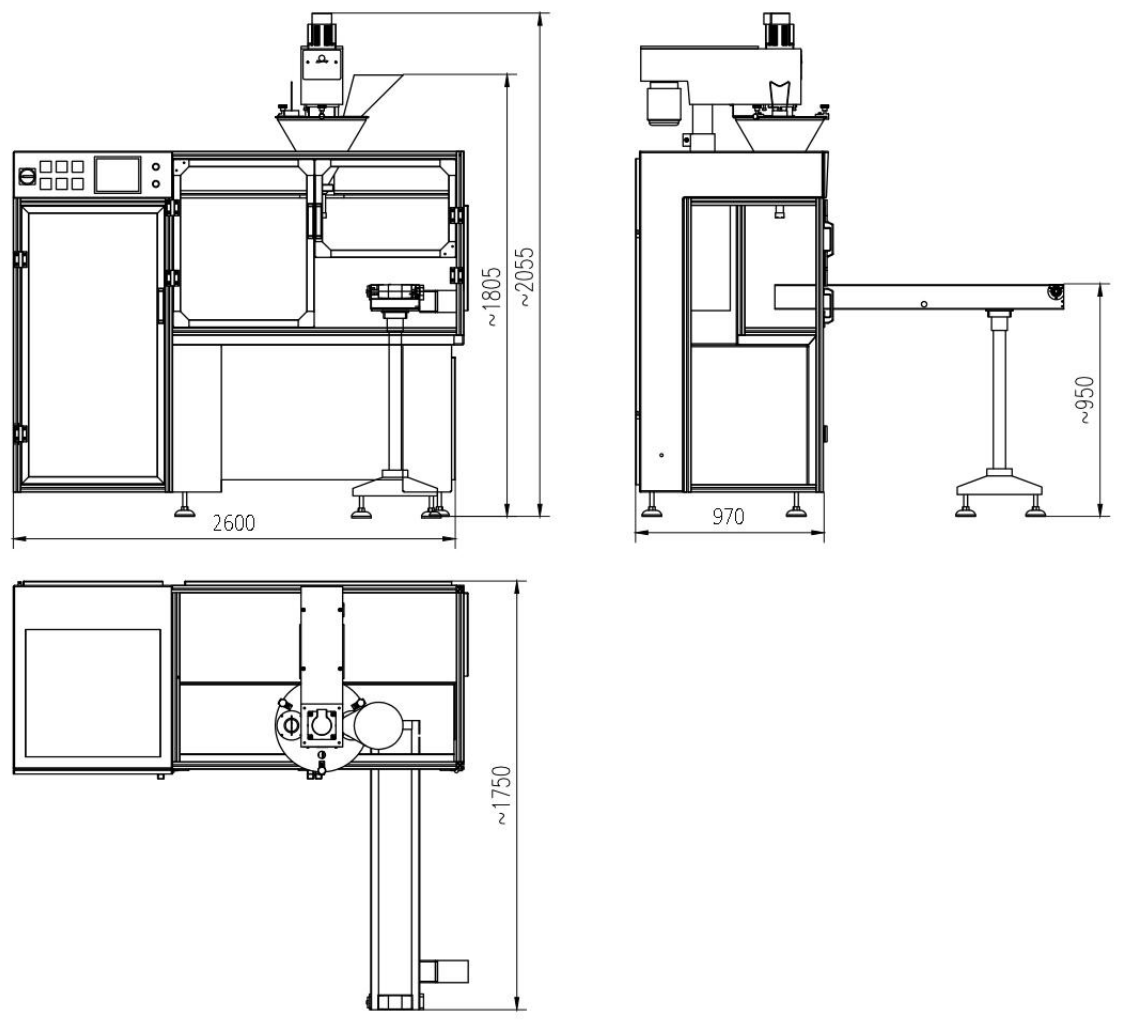

Technical Data	SDXD15
Size range of sachet	70×100~150×200mm
Volume	5~280ml
Output	40-80pouches/min
Consumption	2KWA
Weight	600kg
Dimensions	2600×970×2055mm(L×W×H)

SaintyCo also offer:

Encapsulation Solutions

Tablet Compression Solutions

Coating Systems

Cartoning Systems

Blister Packing Solutions

